



Low voltage AC drives

# ABB component drives

## ACS150

0.5 to 5 hp / 0.37 to 4 kW

### Catalog

Power and productivity  
for a better world™



# ABB component drives

## ABB component drives

ABB component drives are designed to be incorporated into a wide variety of machines such as mixers, conveyors, fans or pumps or anywhere where a fixed speed motor needs to go variable speed motor.

The ABB component drives meet the requirements of OEMs, machinery builders and panel builders. These drives are widely available through the ABB distribution network. The drives are easy to select and provide a range of built-in features as standard including PID control, brake chopper, fixed keypad and speed control potentiometer.

## Highlights

- Worldwide availability through logistical distributors
- User-friendly LCD control panel and integrated potentiometer
- Flexible mounting alternatives
- PID control
- Integrated EMC filter
- Built-in brake chopper
- FlashDrop tool for fast drive commissioning

Feature	Advantage	Benefit
Worldwide availability and service	Drives are available worldwide and permanently stocked in four regions. Dedicated global service and support network that is one of the largest in the industry.	Fast and reliable delivery with dedicated support to any country in the world.
User-friendly LCD control panel and integrated potentiometer	Clear alphanumeric display. Easy set-up and use.	Time savings
Flexible mounting alternatives	Screw or DIN rail mounting, sideways or side-by-side	One drive type can be used in various designs, saving installation costs and time
Integrated EMC filter	High electromagnetic compatibility	Low EMC emissions in selected environments
Built-in brake chopper as standard	No need for an external brake chopper	Space savings, reduced installation cost
FlashDrop tool	Faster and easier drive set up and commissioning for volume manufacturing and maintenance. The FlashDrop tool enables both downloading and uploading drive parameters.	Fast, safe and trouble-free parameter setting without the need to power-up the drive. Patented.
PID control	Varies the drive's performance according to the need of the application.	Enhances production output, stability and accuracy.
Coated boards	Board coating protects the electronics from hazards including static discharge and airborne contaminants, including moisture.	Reduces maintenance due to good protection of electronics components.

# Typical applications

ABB component drives bring speed control benefits to a wide variety of applications.

**In mixing applications** the drive provides high starting torque which benefits the start of the mixing operation. The silent operation mode adjusts the switching frequency of the drive to a higher level after the high-torque start, resulting in lower audible noise. The FlashDrop tool provides a quick and safe way to configure multiple drives for identical mixer applications.

**In conveyors** the belt speed can be controlled using a drive and a motor. Production lines often have multiple stages, including conveyors, which need to be efficiently linked with each other to provide high production output. A drive provides smooth start and stop of the conveyor, thereby reducing mechanical stress and lowering maintenance costs.

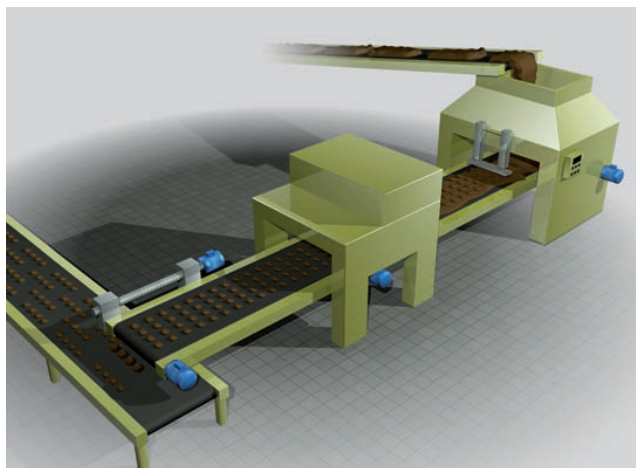

**A heat pump system** consists of an indoor unit with fan and an outdoor unit with a compressor and a blower. The heat pump cools indoor environment by gathering heat from air, and transferring the heat to air outside. The outdoor unit uses the compressor and the blower to dissipate the heat. The cooled air is blown indoors by fans located in the indoor unit. Drive allows the user to variably control the cooling power based on customer request. AC drives optimizes systems' energy efficiency and smoothens system operation.

**Fans** are used for process cooling and ventilation in industrial, commercial and domestic environments. Using a drive to control air flow enables energy savings compared to mechanical flow control methods. An ABB drive has integrated PID control which provides optimal air flow by adjusting the fan speed based on a given reference value. Compact size and various mounting methods enable flexible system design.

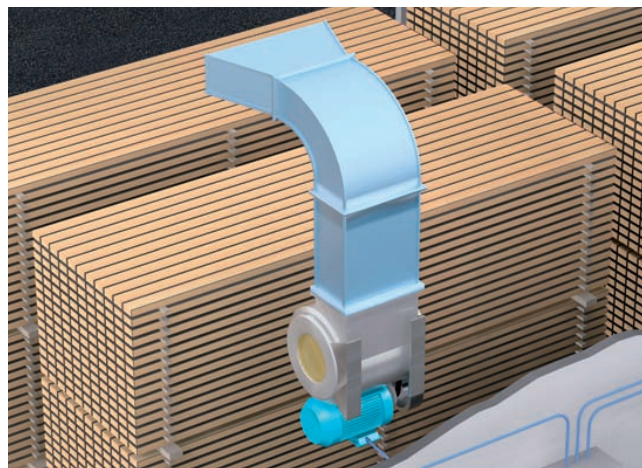
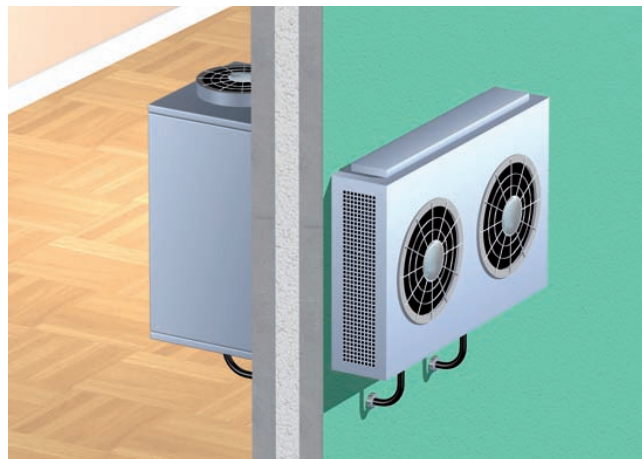

# Ratings, types and dimensions

## Type designation

In column 4 on the right is the unique reference number that clearly identifies your drive by power rating and frame size. Once you have selected the type designation, the frame size (column 5) can be used to determine the drives dimensions, shown below.

## Voltages

ACS150 is available in two voltage ranges:

2 = 200 to 240 V

4 = 380 to 480 V

Insert either "2" or "4", depending on your chosen voltage, into the type designation shown on the right.

## Construction

"01U" and "03U" within the type designation varies depending on the drive phase. Choose below the one you need.

01 = 1-phase

03 = 3-phase

U = EMC filter disconnected, 60 Hz frequency

(In case the filter is required it can easily be connected.)

Ratings			Type designation	Frame size
$P_N$ hp	$P_N$ kW	$I_{2N}$ A		
<b>1-phase supply voltage 200 to 240 V units</b>				
0.5	0.37	2.4	ACS150-01U-02A4-2	R0
1	0.75	4.7	ACS150-01U-04A7-2	R1
1.5	1.1	6.7	ACS150-01U-06A7-2	R1
2	1.5	7.5	ACS150-01U-07A5-2	R2
3	2.2	9.8	ACS150-01U-09A8-2	R2
<b>3-phase supply voltage 200 to 240 V units</b>				
0.5	0.37	2.4	ACS150-03U-02A4-2	R0
0.75	0.55	3.5	ACS150-03U-03A5-2	R0
1	0.75	4.7	ACS150-03U-04A7-2	R1
1.5	1.1	6.7	ACS150-03U-06A7-2	R1
2	1.5	7.5	ACS150-03U-07A5-2	R1
3	2.2	9.8	ACS150-03U-09A8-2	R2
<b>3-phase supply voltage 380 to 480 V units</b>				
0.5	0.37	1.2	ACS150-03U-01A2-4	R0
0.75	0.55	1.9	ACS150-03U-01A9-4	R0
1	0.75	2.4	ACS150-03U-02A4-4	R1
1.5	1.1	3.3	ACS150-03U-03A3-4	R1
2	1.5	4.1	ACS150-03U-04A1-4	R1
3	2.2	5.6	ACS150-03U-05A6-4	R1
5	4	8.8	ACS150-03U-08A8-4	R1

X within the type code stands for E or U.

## Cabinet-mounted drives (UL open)

Frame size	IP20 UL open					
	H1 in	H2 in	H3 in	W in	D in	Weight lb
R0	6.65	7.95	9.41	2.76	5.59	2.5
R1	6.65	7.95	9.41	2.76	5.59	2.9
R2	6.65	7.95	9.41	4.13	5.59	3.3

H1 = Height without fastenings and clamping plate.

H2 = Height with fastenings but without clamping plate.

H3 = Height with fastenings and clamping plate.

W = Width

D = Depth

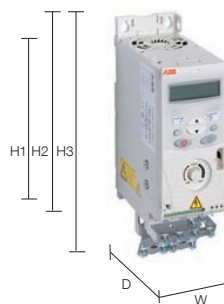

## Wall-mounted drives (NEMA 1)

Frame size	NEMA 1				
	H4 in	H5 in	W in	D in	Weight lb
R0	10.12	11.02	2.76	5.59	3.3
R1	10.12	11.02	2.76	5.59	3.75
R2	10.12	11.1	4.13	5.59	4.2

H4 = Height with fastenings and NEMA 1 connection box.

H5 = Height with fastenings, NEMA 1 connection box and hood.

W = Width

D = Depth



# Technical data

Mains connection	
<b>Voltage and power range</b>	1-phase, 200 to 240 V $\pm$ 10% 0.5 to 3 hp (0.37 to 2.2 kW) 3-phase, 200 to 240 V $\pm$ 10% 0.5 to 3 hp (0.37 to 2.2 kW) 3-phase, 380 to 480 V $\pm$ 10% 0.5 to 5 hp (0.37 to 4 kW)
<b>Frequency</b>	48 to 63 Hz
Motor connection	
<b>Voltage</b>	3-phase, from 0 to $U_{supply}$
<b>Frequency</b>	0 to 500 Hz
<b>Continuous loading capability</b> (constant torque at a max. ambient temperature 40 °C)	Rated output current $I_{2N}$
<b>Overload capability</b> (at a max. ambient temperature of 40 °C)	At heavy duty use $1.5 \times I_{2N}$ for 1 minute every 10 minutes At start $1.8 \times I_{2N}$ for 2 s
<b>Switching frequency</b>	
Default	4 kHz
Selectable	4 to 16 kHz with 4 kHz steps
<b>Acceleration time</b>	0.1 to 1800 s
<b>Deceleration time</b>	0.1 to 1800 s
<b>Braking</b>	Built-in brake chopper as standard
<b>Motor control method</b>	Scalar U/f
Environmental limits	
<b>Ambient temperature</b>	14 to 104 °F (-10 to 40 °C), no frost allowed, 122 °F (50 °C) with 10% derating
<b>Altitude</b>	
Output current	Rated current available at 0 to 3281 ft (0 to 1000 m) reduced by 1% per 328 ft (100 m) over 3281 to 6562 ft (1000 to 2000 m)
<b>Relative humidity</b>	Lower than 95% (without condensation)
<b>Degree of protection</b>	IP20 / Optional NEMA 1 enclosure
<b>Enclosure colour</b>	NCS 1502-Y, RAL 9002, PMS 420 C
<b>Contamination levels</b>	IEC 721-3-3
Transportation	No conductive dust allowed Class 1C2 (chemical gases) Class 1S2 (solid particles)
Storage	Class 2C2 (chemical gases) Class 2S2 (solid particles)
Operation	Class 3C2 (chemical gases) Class 3S2 (solid particles)

Programmable control connections	
<b>One analog input</b>	
Voltage signal	0 (2) to 10 V, $R_{in} > 312 \text{ k}\Omega$
Current signal	0 (4) to 20 mA, $R_{in} = 100 \Omega$
Potentiometer reference value	10 V $\pm$ 1% max. 10 mA, $R < 10 \text{ k}\Omega$
Resolution	0.1%
Accuracy	$\pm$ 2%
<b>Auxiliary voltage</b>	24 V DC $\pm$ 10%, max. 200 mA
<b>Five digital inputs</b>	12 to 24 V DC with internal or external supply, PNP and NPN, pulse train 0 to 16 kHz
Input impedance	2.4 k $\Omega$
<b>One relay output</b>	
Type	NO + NC
Maximum switching voltage	250 V AC/30 V DC
Maximum switching current	0.5 A/30 V DC; 5 A/230 V AC
Maximum continuous current	2 A rms
Product compliance	
Low voltage Directive 2006/95/EC with supplements	
Machinery Directive 2006/42/EC	
EMC Directive 2004/108/EC with supplements	
Quality assurance system ISO 9001	
Environmental system ISO 14001	
UL, cUL, CE, C-Tick and GOST R approvals	
RoHS compliant	

# Control connections and interfaces

## Application macros

Application macros are preprogrammed parameter sets. When starting up the drive, the user typically selects one of the macros that is best suited for the application. The diagram below gives an overview of ACS150 control connections and shows the default I/O connections for the ABB standard macro.

ABB component drives have six standard macros:

- ABB standard macro
- 3-wire macro
- Alternate macro
- Motor potentiometer macro
- Hand/auto macro
- PID control macro

In addition to the standard macros the user can create three user macros. The user macro allows the user to save the parameter settings for later use.

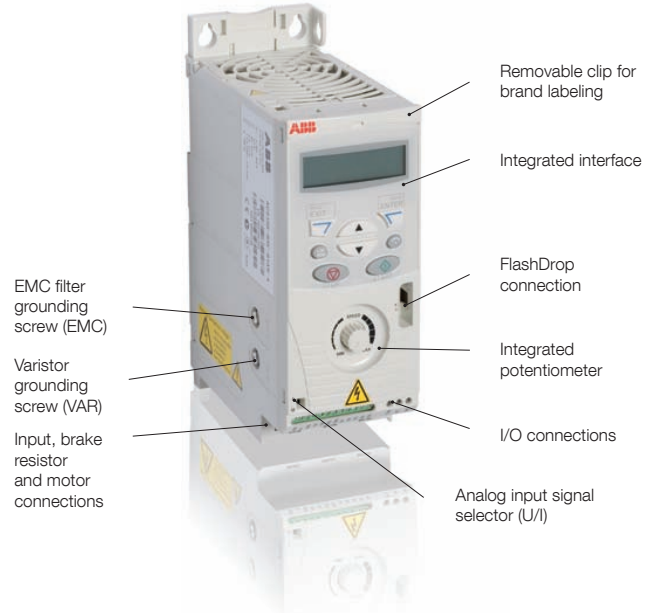

## Typical I/O connections

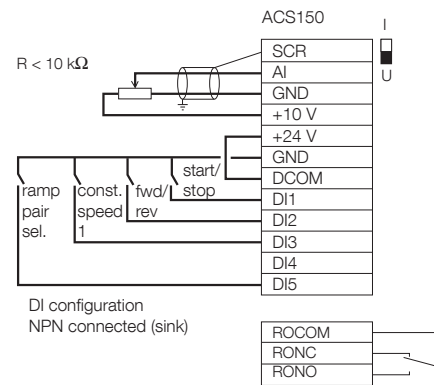
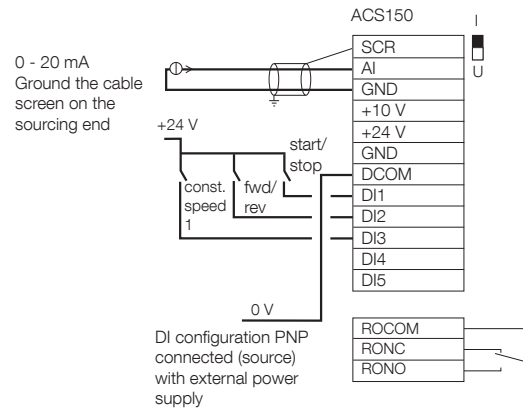
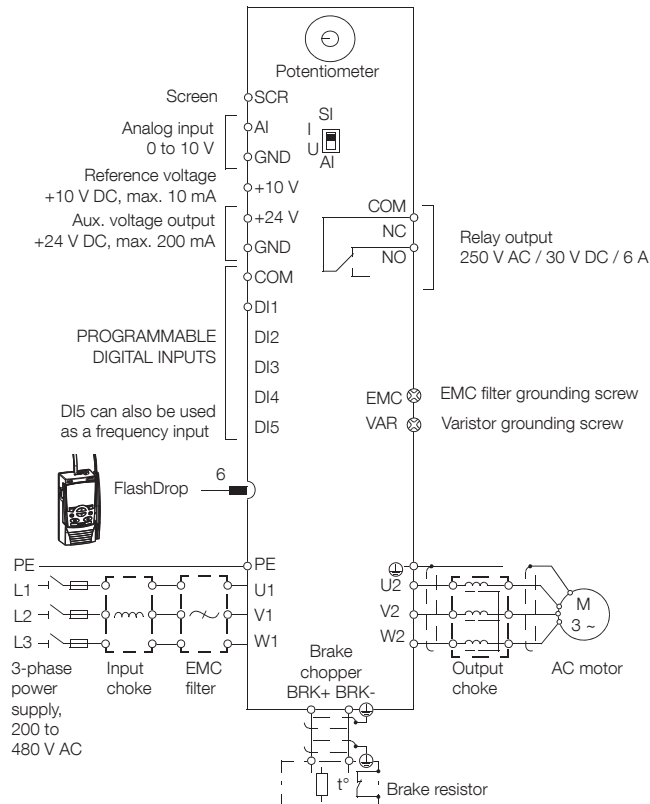



# Cooling and fuses

## Cooling

ACS150 is fitted with cooling fans as standard. The cooling air must be free from corrosive substances and must not be above the maximum ambient temperature of 104 °F (122 °F with derating). For more specific limits see the Technical data - Environmental limits in this catalog.

### Cooling air flow

Type designation	Frame size	Heat dissipation		Air flow	
		[W]	BTU/hr	ft <sup>3</sup> /min	m <sup>3</sup> /h
<b>1-phase supply voltage 200 to 240 V units</b>					
ACS150-01U-02A4-2	R0	25	85	-*)	-*)
ACS150-01U-04A7-2	R1	46	157	14	24
ACS150-01U-06A7-2	R1	71	242	14	24
ACS150-01U-07A5-2	R2	73	249	12	21
ACS150-01U-09A8-2	R2	96	328	12	21
<b>3-phase supply voltage 200 to 240 V units</b>					
ACS150-03U-02A4-2	R0	19	65	-*)	-*)
ACS150-03U-03A5-2	R0	31	106	-*)	-*)
ACS150-03U-04A7-2	R1	38	130	14	24
ACS150-03U-06A7-2	R1	60	205	14	24
ACS150-03U-07A5-2	R1	62	212	12	21
ACS150-03U-09A8-2	R2	83	283	12	21
<b>3-phase supply voltage 380 to 480 V units</b>					
ACS150-03U-01A2-4	R0	11	38	-*)	-*)
ACS150-03U-01A9-4	R0	16	55	-*)	-*)
ACS150-03U-02A4-4	R1	21	72	8	13
ACS150-03U-03A3-4	R1	31	106	8	13
ACS150-03U-04A1-4	R1	40	137	8	13
ACS150-03U-05A6-4	R1	61	208	11	19
ACS150-03U-08A8-4	R1	94	321	14	24

\*) Frame size R0 with free convection cooling.

### Free space requirements

Enclosure type	Space above in	Space below in	Space on left/right in
All frame sizes	2.95	2.95	0

## Fuses

Standard fuses can be used with ABB component drives. For input fuse connections see table below.

### Selection table

Type designation	Frame size	IEC Fuses		UL fuses	
		[A]	Fuse type*)	[A]	Fuse type*)
<b>1-phase supply voltage 200 to 240 V units</b>					
ACS150-01U-02A4-2	R0	10	gG	10	UL class T
ACS150-01U-04A7-2	R1	16	gG	20	UL class T
ACS150-01U-06A7-2	R1	20	gG	25	UL class T
ACS150-01U-07A5-2	R2	25	gG	30	UL class T
ACS150-01U-09A8-2	R2	35	gG	35	UL class T
<b>3-phase supply voltage 200 to 240 V units</b>					
ACS150-03U-02A4-2	R0	10	gG	10	UL class T
ACS150-03U-03A5-2	R0	10	gG	10	UL class T
ACS150-03U-04A7-2	R1	10	gG	15	UL class T
ACS150-03U-06A7-2	R1	16	gG	15	UL class T
ACS150-03U-07A5-2	R1	16	gG	15	UL class T
ACS150-03U-09A8-2	R2	16	gG	20	UL class T
<b>3-phase supply voltage 380 to 480 V units</b>					
ACS150-03U-01A2-4	R0	10	gG	10	UL class T
ACS150-03U-01A9-4	R0	10	gG	10	UL class T
ACS150-03U-02A4-4	R1	10	gG	10	UL class T
ACS150-03U-03A3-4	R1	10	gG	10	UL class T
ACS150-03U-04A1-4	R1	16	gG	15	UL class T
ACS150-03U-05A6-4	R1	16	gG	15	UL class T
ACS150-03U-08A8-4	R1	20	gG	25	UL class T

\*) According to IEC-60269 standard.

# Options

## FlashDrop tool

FlashDrop is a powerful palm sized tool for fast and easy parameter selecting and setting. It gives the possibility to hide selected parameters to protect the machine. Only the parameters needed in the application are shown. The tool can copy parameters between two drives or between a PC and a drive. All the above can be done without a power connection to the drive – in fact, it is not even necessary to unpack the drive.

## DrivePM

DrivePM (Drive parameter manager) is a tool to create, edit and copy parameter sets for FlashDrop. For each parameter/group the user has a possibility to hide it, which means that the drive user does not see the parameter/group at all.

## DrivePM requirements

- Windows 2000/XP/Vista/Windows 7
- Free serial port from a PC

## FlashDrop package includes

- FlashDrop tool
- DrivePM software on a CD-rom
- User's manual in pdf-format on the previous CD-rom
- Cable for connection between the PC and FlashDrop
- Battery charger



## Protection class NEMA 1

The NEMA 1 kit includes a connection box for finger protection, conduit tube installation, and a hood for protection against dirt and dust.

## Brake resistors

All ACS150 drives are configured with a built-in brake chopper capable of 100% braking. By connecting an external resistor, you can enable the dynamic braking function. The minimum and maximum resistance and the required power is show in the table. Ensure the resistor purchased does not exceed the maximum resistance nor is smaller than the minimum resistance. For more information about the selection of brake resistors, see the ACS150 User's Manual ( 3AFE68576032) and PowerOhm Resistor Inc Price List (LVD-PNPL02U-EN).



# Notes

A series of horizontal dotted lines for taking notes.

# Contact us

[www.abb.us/drives](http://www.abb.us/drives)

© Copyright 2011 ABB. All rights reserved.  
Specifications subject to change without notice.

3AUA0000086631 REV E US 4.3.2011 ACS150-PHTC01U-EN

Power and productivity  
for a better world™ 

Proudly Distributed by Gross Automation | (877) 268-3700  
[www.abbdrivesales.com](http://www.abbdrivesales.com) | [sales@grossautomation.com](mailto:sales@grossautomation.com)